

Technical sheet :

MRT 1840 EASY 3B S2 360°



Capacities		Metric
Max. capacity		4000 kg
Max. lifting height		17.90 m
Weight and dimensions		
Overall width	b1	2.40 m
Overall height	h17	2.97 m
Overall cab width	b4	0.95 m
Ground clearance	m4	0.34 m
Wheelbase	y	2.32 m
Frame leveling longitudinal +/-		0 °
Tilt-up angle	a4	12 °
Tilt-down angle	a5	105 °
Turret rotation		400 °
Overall weight		13670 kg
Forks length / width / section	l / e / s	1200 mm x 125 mm x 15 mm
Wheels		
Tires type		Pneumatic
Standard tires		Camso - 14PR 4LR1 A8 158 - 405/70-20
Drive wheels (front / rear)		2 / 2
Stabilisers		
Stabilizers Type		Wing Type
Controls for stabs		Stabs Commands Individual or Simultaneous
Engine		
Engine brand		Perkins
Engine norm		Stage IIIB
Engine model		854 E-E 34 TA
Engine power (Hp) / power (kW) / rotation		102 Hp / 75 kW @ 1200 rpm
Max. torque		1400 Nm
Number of cylinders - Capacity of cylinders		3400 - 3400 cm³
Injection		engine Injection direct
Engine cooling system		Water
Electric circuit		
12V Battery capacity		120 Ah
Transmission		
Number of gears (forward / reverse)		2 / 2
Drawbar pull		8600 daN
Parking brake		Automatic Negative Hand-brake
Hydraulics		
Hydraulic pump type		Gear pump
Hydraulic flow		115 l/min
Hydraulic Pressure		270 bar
Hydraulic tank capacity		150 l
Tank capacities		
Engine oil		150 l
Fuel		130 l
Noise and vibration		
Noise at driving position (LpA)		79.70 dB
Noise to environment (LwA)		104 dB
Vibration on hands/arms		2.50 m/s²
Miscellaneous		
Steering wheels (front / rear)		2 / 2
Controls		2 Joysticks
Cab certification		Cabin ROPS - FOPS level 2
Attachment recognition system (E-Reco)		Standard

MRT 1840 Easy 3B S2 360° - Dimensional drawing

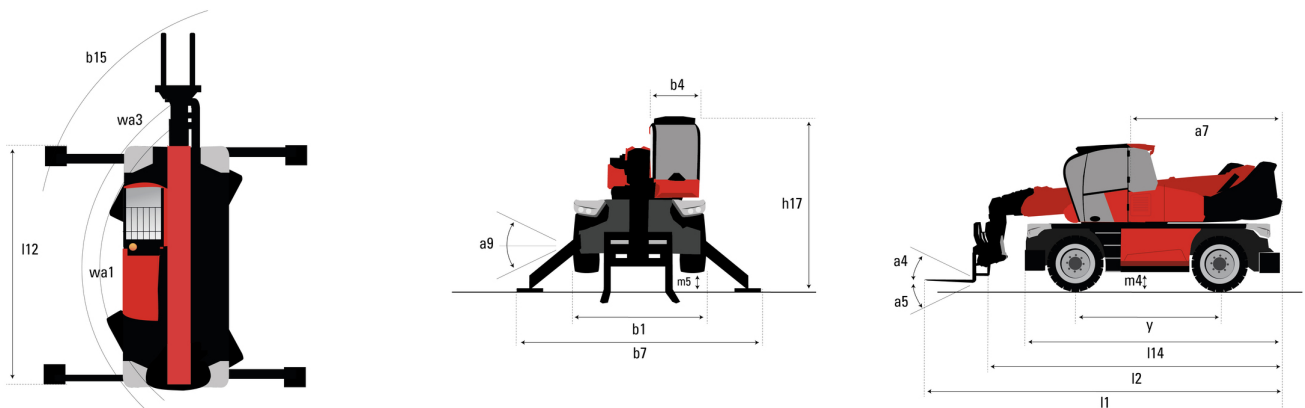

Other data		Metric
Length of frame	l14	4.35 m
Wheelbase	y	2.32 m
Ground clearance	m4	0.34 m
Counterweight offset (turret at 90°)	a7	2.49 m
Outer turning radius (with forks)	b15	3.90 m
Overall width with stabilisers extended	b7	3.98 m
Frame leveling corrector	a9	0 °



Head Office

B.P. 249 - 430 rue de l'Aubinière

44150 Ancenis Cedex - France

Tel: +33 (0)2 40 09 10 11 - Fax: +33 (0)2 40 09 10 97

www.manitou.com



This publication provides a description of the configuration versions and options for Manitou products, which may differ for equipment. The equipment presented in this brochure may be part of a series, as an option, or it may not be available, depending on the versions. Manitou reserves the right, at any time and without notice, to amend the specifications described and represented. The specifications provided do not bind the manufacturer. For more details, please contact your Manitou agent. This is not a contractually binding document. The presentation of the products is not contractually binding. List of specifications non-exhaustive. The logos as well as the visual identity of the company are owned by Manitou and cannot be used without authorisation. All rights reserved. The photos and diagrams contained in this brochure are only provided for consultation and information purposes.

MANITOU BF SA - Limited company with board of directors - Share capital: 39,668,399 euros - 857 802 508 RCS Nantes